

## Power Vented Water Heaters

Lochinvar's Power Vented models are available in capacities of 75 gallons and feature a powered exhaust fan for sidewall venting with PVC material. All models meet or exceed the ASHRAE Energy Efficiency Standards.

### Standard Features

- **Power Vented Exhaust System** - The 120 VAC blower fan exhausts the by-products of combustion directly to the outside the building through PVC style pipe, eliminating the need for conventional chimneys or roof penetrations.
- **Side Wall Venting** - can be vented horizontally with 3" or 4" PVC, or CPVC vent pipe, depending on the model.  
*(See vent chart for max. vent lengths)*
- **Vertical Venting** - can be vented vertically with 3" or 4" PVC or CPVC vent pipe, depending on the model.  
*(See vent chart for max. vent lengths)*
- **Electronic Spark Ignition** - Eliminates nuisance pilot outages and saves fuel by eliminating the continuously burning pilot, while providing solid-state ignition.
- **Low NOx Burner** - This whisper quiet, 360° burner incorporates aluminized steel into its die-formed design. The large burner diameter transfers more heat, while providing clean and efficient combustion. Satisfies local codes and emissions standards.
- **Non-CFC Foam Insulation** - Improved formulation provides uniform tank coverage with a thick blanket of insulating foam. This non-CFC polyurethane closed cell foam minimizes standby losses and maximizes heat retention.
- **Glass-Lined Steel Tank** - The tank is automatically formed, rolled, and welded to ensure a continuous seam for the glass lining. The durable glass lining is fused to the interior of the tank at 1600°F to assure lasting protection against rust and corrosion while providing clean hot water.
- **Magnesium Tank Saver Anode** - High capacity anode rod provides protection from the effects of electrolytic corrosion.
- **Heat Traps** - Factory installed, minimizes heat loss through piping.
- **Adjustable Thermostat** - This accurate control provides an easy way to reset water temperature for best economy. Automatic over-heat safety device is standard.
- **Dielectric Nipples** - Factory installed waterways protect the tank from the corrosive action between dissimilar metals, while providing piping convenience.
- **Side Connections for Space Heating** - models are equipped with side tappings for space heating applications.
- **Temperature & Pressure Relief Valve**
- **Brass Drain Valve**
- **Warranty** - Six year limited tank warranty.  
Six year warranty on parts. (See warranty for details)  
Ten year limited tank warranty upgrade available.



# Power Vent Gas Water Heater Dimensions and Specifications:

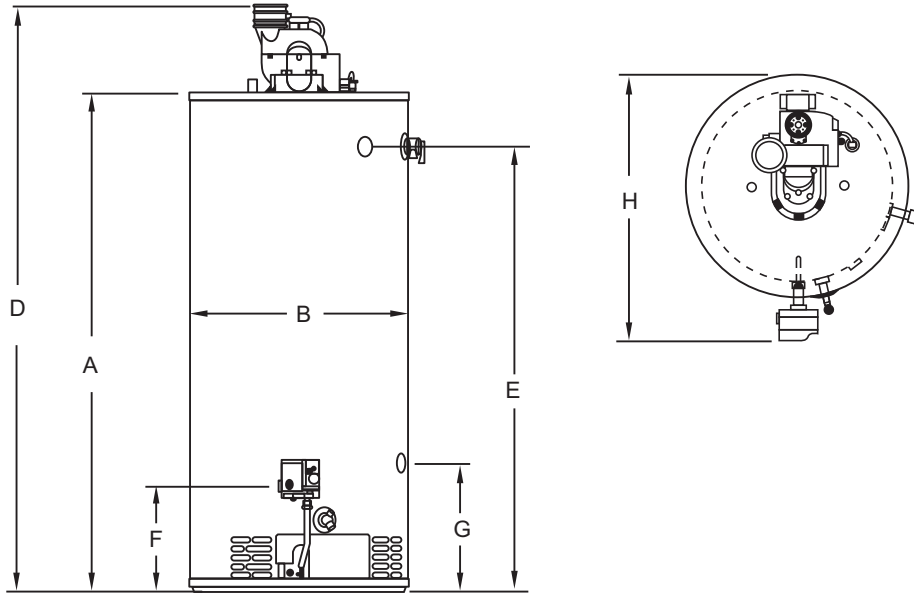

Model Number	Natural Gas			LP Gas			A	B	D	E	F	G	H	Vent Size	Ship. Wt.
	Gal. Cap.	Btu/hr Input	GPH @ 90°F Rise	Btu/hr Input	GPH @ 90°F Rise										
LVN076	75	76,000	82	75,100	82	59"	26"	68-1/2"	51-3/4"	14"	16-3/4"	31"	3"	246	

**Notes:** Replace "N" with "L" to indicate LP gas model.  
 All gas connections are 1/2".  
 This model is certified to ANSI Z21.10.3

"L" prefix indicates 6 year tank warranty.  
 All water connections are 3/4" NPT.  
 This model is not required to meet the NAECA or FVIR standard.

## Max. Equivalent Vent Length

	Horizontal		Vertical	
	3"	4"	3"	4"
LVN076	50'	80'	50'	80'

## FOR EASE IN ORDERING BY MODEL NUMBER

LV	N	076
Power Vented	Natural Gas	Gallon Capacity

This is a Power Vented, residential, natural gas 75 gallon water heater.

## Certified for Potable Water and Space Heating Applications

This water heater is suitable for water heating and space heating. Toxic chemicals, such as those used for boiler water treatment shall NEVER be introduced into this system. This water heater may NEVER be connected to any existing heating system or components previously used with non-potable water heating appliances.

All models available with a Six Year Limited Warranty Against Tank Failure. All parts are warranted for six years. Three year limited warranty on all models when installed in a commercial application. (A Ten Year Limited Tank Warranty upgrade is available.)



**Lochinvar**<sup>®</sup>  
 High Efficiency Water Heaters, Boilers and Pool Heaters



Lochinvar Corporation • 300 Maddox Simpson Pkwy • Lebanon, TN 37090 • 615-889-8900 / Fax: 615-547-1000

www.Lochinvar.com